

IR SENS^{PRO} SERIES

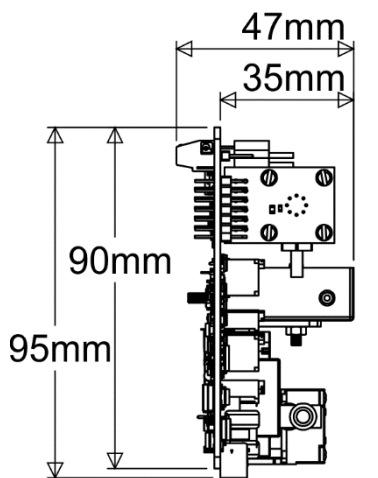

SIDE VIEW

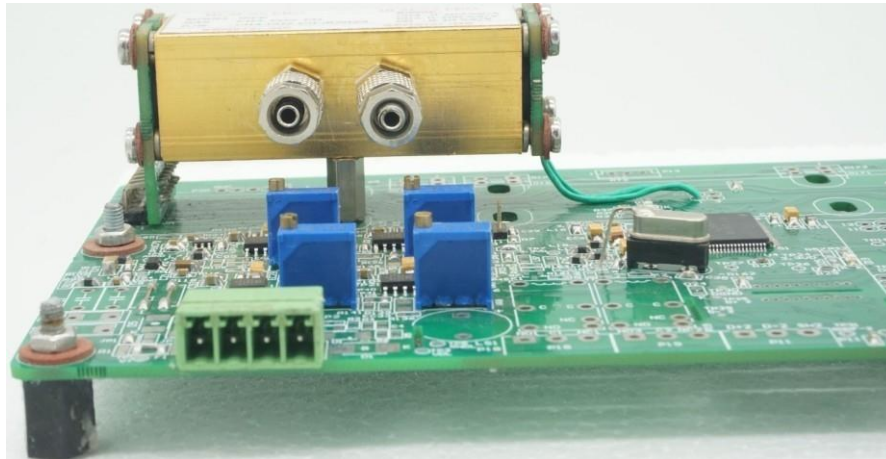
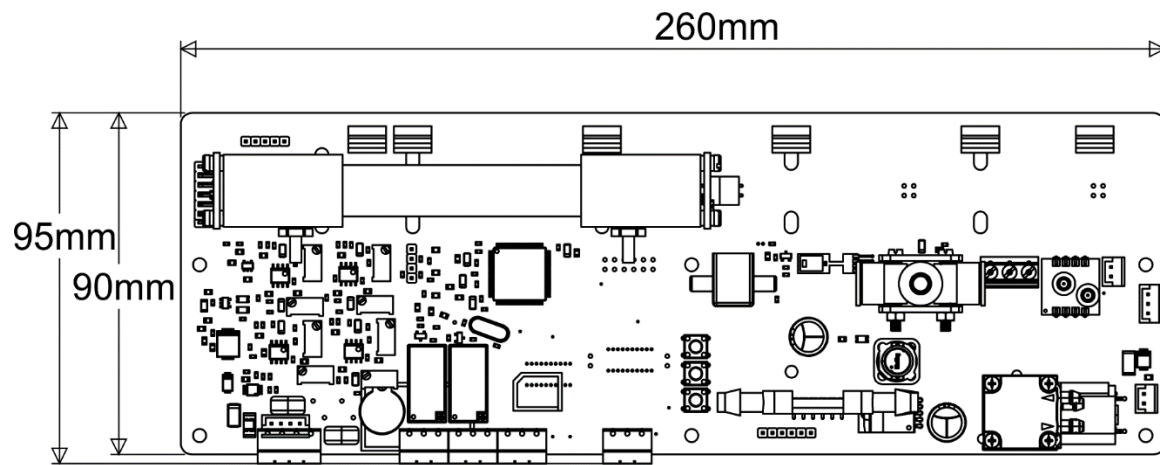

TOP VIEW

NOTE: BENCH SIZE MAY VARY AS PER GAS RANGE

GAS Analysis the Smarter way... High Precision & Durable Sensors.....

We are highly Focused on Customized Solution & Maintaining the highest quality standards with exceptional customer service.

IR SENSE^{PRO}

Infrared Gas Sensor Methane CH₄: 100 % LEL

- Pre Calibrated
- Compact Design
- 3/5 mm gas line connector
- 9 VDC to 30 VDC Supply Voltage
- Status indicated by LED
- Low drift



Features:

- Measuring Principle** : Non- Dispersive Infra-Red
Measurement Range: 0 – 100 % LEL Full Scale
Flow Rate : 0.5 - 0.8 LPM
Warm-up time : 180 sec.
Accuracy : < 5% of Reading or $\pm 0.5\%$ LEL Whichever is More

Specification:

- **Digital Resolution** : 0.1% LEL
- **Response Time** : 10 Sec. @ 0.5 LPM
- **T90 (10 to 90 % FS)** : 30 Sec. @ 0.5 LPM
- **Repeatability** : $\pm 2\%$ LEL
- **Linearity Error** : $\pm 2\%$ LEL
- **Long term stability (Zero)** : $\leq \pm 1\%$ LEL
- **Long term stability (Span)** : $\leq \pm 2\%$ LEL

Electrical Specification:

- **Supply Voltage** : 9 VDC to 30 VDC
- **Supply Current (Peak)** : < 200 mA @ 9 V
- **Digital Output Signal** : MODBus Protocol RS485 / UART
- **Calibration** : Zero and span

Environmental Conditions:

- **Operating Temperature** : 0 to + 50°C
- **Storage Temperature** : -20 to +60°C
- **Air Pressure** : 800 to 1100 hPa
- **Ambient Humidity** : 0-95 % Relative Humidity (Not Condensing)

Temp, Pressure Effects:

- **Temp. Dependence (Zero)** : $\leq \pm 0.1\%$ LEL
- **Temp. Dependence (Span)** : $\leq \pm 0.2\%$ LEL
- **Pressure Dependence** : + 0.121% per 10 hPa
- **Sampling** : Particle free and clean sample gas

Some Typical Applications:

- Process Measurement Technology
- CH₄ Analyzers
- Fruit Storage & Ripening Gas Control
- Emission Measurement
- Process Control

For other gases, please contact our sales team