

RYS8833

Ultra Low Power 1.8V UART/I2C interface GNSS module

Datasheet



11mm*8mm*2.2mm



PRODUCT DESCRIPTION

The RYS8833 is a multi-GNSS module with high sensitivity, The RYS8833 also has integrated digital noise filters and spectrum analyzer.

FEATURES

- SONY CXD5605AGF Engine.
- A multi-GNSS module for GPS(L1 C/A), GLONASS(L1 OF), SBAS(L1 C/A), QZSS(L1 C/A), BeiDou(B1) and Galileo(E1 CBOC).
- Including SAW filter, LNA and TCXO.
- Embedded digital noise filters and spectrum analyzer.
- UART / I2C Interface optional.

BLOCK DIAGRAM

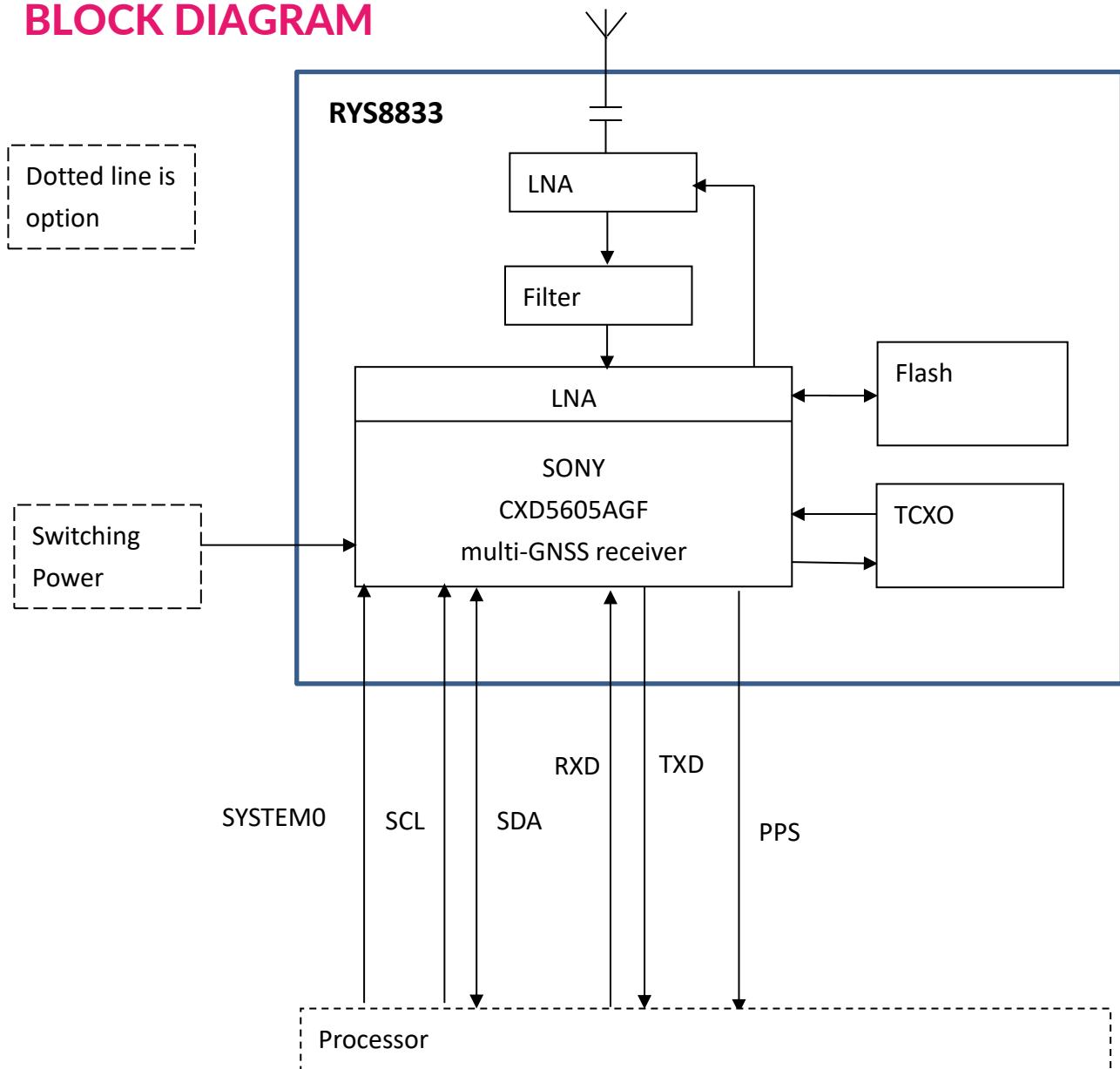

PIN DESCRIPTION

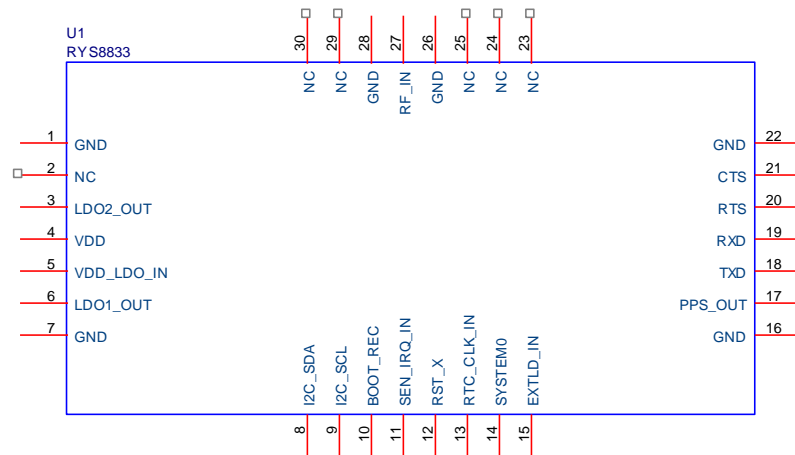

Pin	Name	I/O	Condition
1,7,16,22,26,28	GND	-	Ground
2,23,24,25,29,30	NC	-	Leave Unconnected.
3	LDO2_OUT	O	LDO output for memory core blocks.
4	VDD	I	Power Supply and I/O Voltage.
5	LDO_IN	I	LDO0 / LDO1 Input
6	LDO1_OUT	O	LDO output for digital block.
8	I2C_SDA	I/O	I2C SDA *If not used, Please Leave Unconnected.
9	I2C_SCL	I/O	I2C SCL *If not used, Please Leave Unconnected.
10	BOOT_REC	I/O	BOOT Recovery. *If not used, Please connect to GND.
11	SEN_IRQ_IN	I	Interrupt input. *If not used, Please Leave Unconnected.
12	RST_X	I	Reset input.
13	RTC_CLK_IN	I	*Please connect GND if it is not in used
14	SYSTEM0	I	VDD : UART Interface, GND : I2C Interface.
15	EXTLD_IN	I	Timing signal input, from LTE module. *If not used, Please Leave Unconnected.
17	PPS_OUT	O	Time pulse output.
18	TXD/SCL	O	Serial interface Output / I2C interface
19	RXD/SDA	I/O	Serial interface Input / I2C interface
20	Reversed	-	Leave Unconnected.
21	Reversed	-	Leave Unconnected.
27	RF_IN	I	GNSS RF Signal input.

APPLICATION SCHEMATIC (UART Interface)

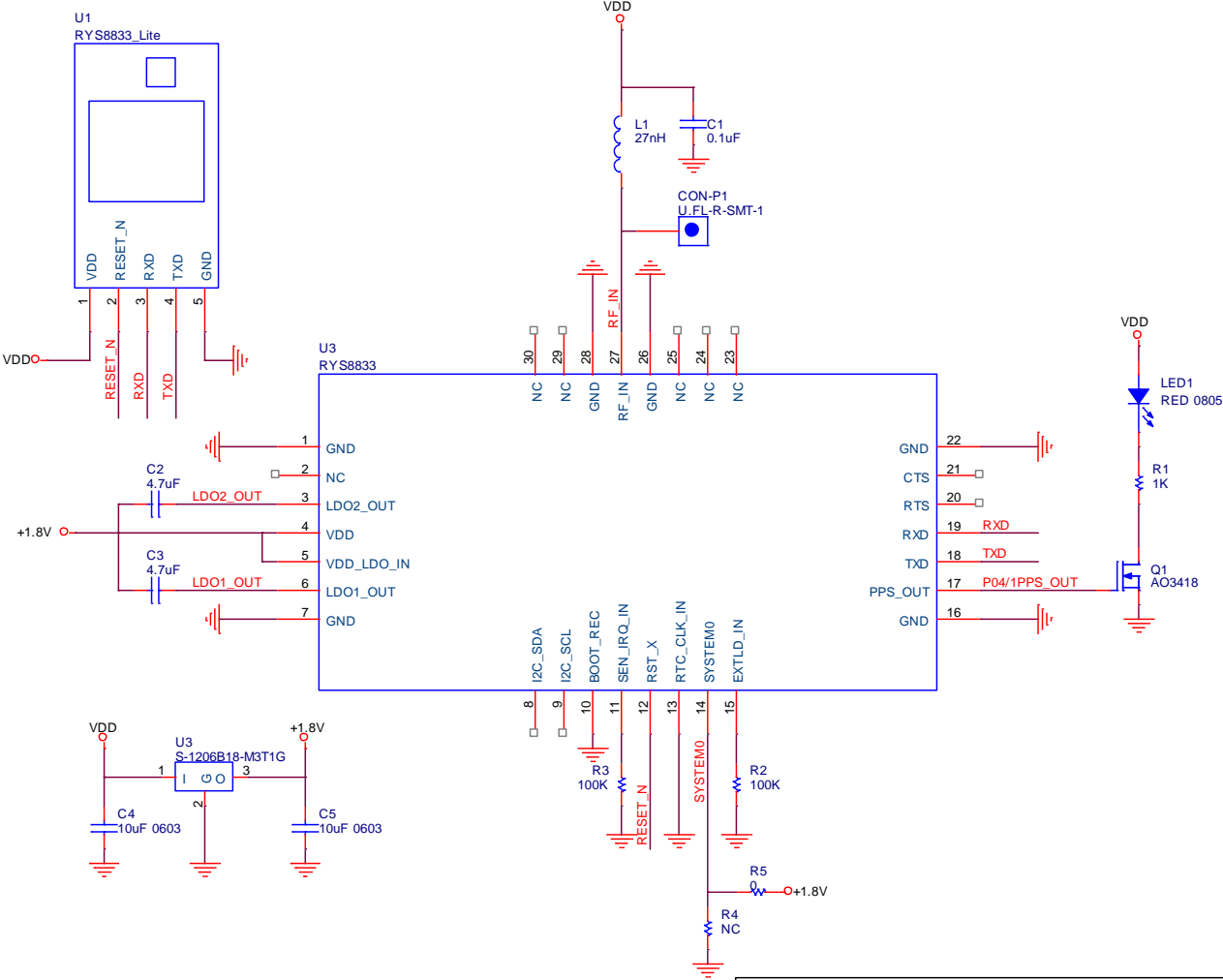

Title		
RYS8833_Lite		
Size	Document Number	Rev
Custom>Doc>		1.1
Date:	Tuesday, September 01, 2020	Sheet 1 of 1

APPLICATION SCHEMATIC (Use buck regulator)

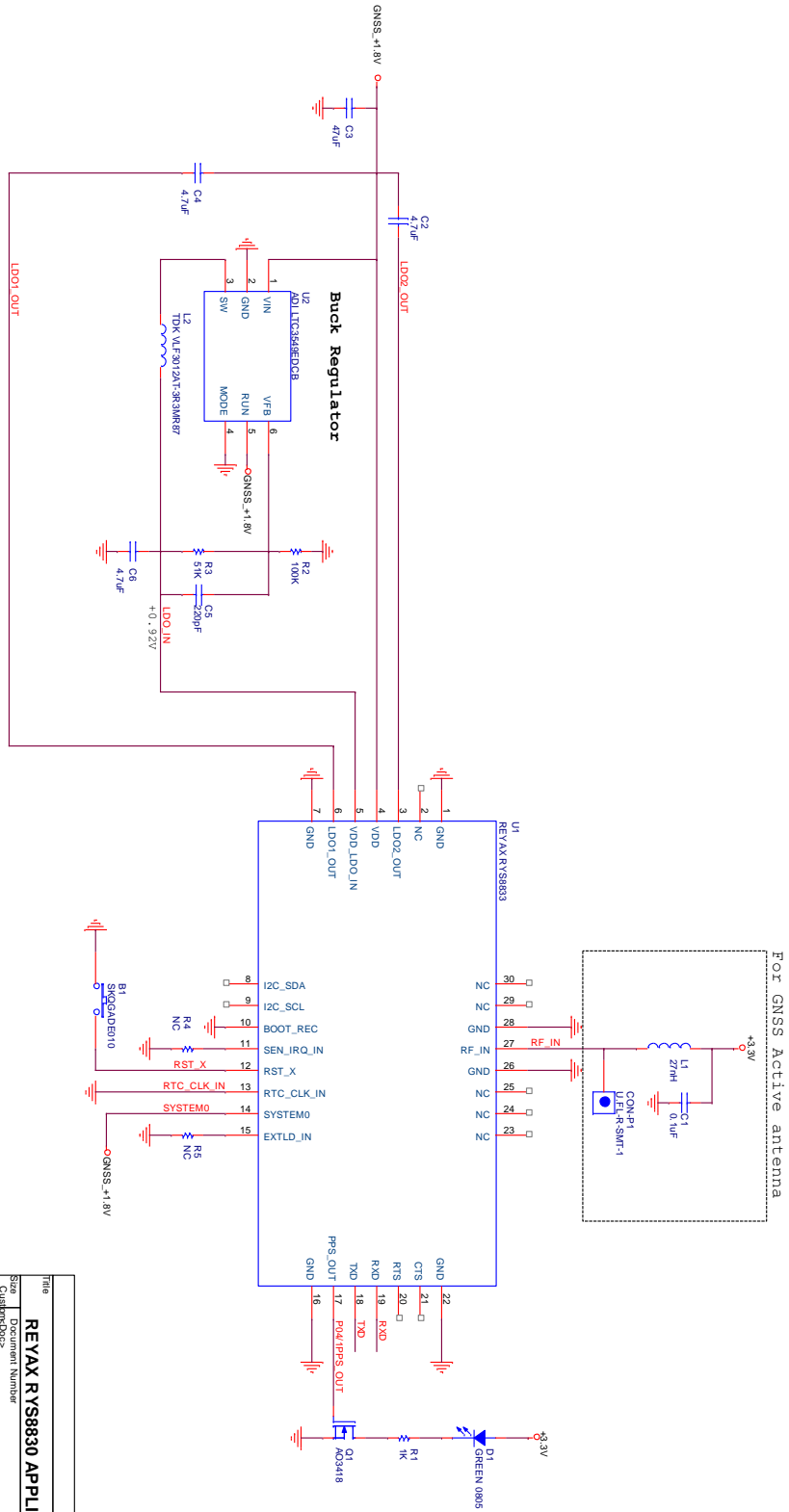

Title	REYAX RYS88330 APPLICATION
Size	Document Number
Version	00000000
Date	Thursday, October 07, 2021
Sheet	1 of 1
Rev	1.0

SPECIFICATION

Item	Min.	Typical	Max.	Unit	Condition
Power Supply Voltage	1.71	1.8	1.89	V	VDD
	0.9	1.8	1.95	V	VDD_LDO_IN
GNSS continuous mode					
Satellite acquisition Current		19		mA	
Satellite tracking Current		13		mA	
Idle Current		3.7		mA	Waiting for command
Sleep2 mode current		0.2		mA	
Satellite acquisition Current		11.5		mA	Use buck regulator
Satellite tracking Current		8.2		mA	Use buck regulator
Idle Current		3.3		mA	Use buck regulator
Sleep0 mode current		0.5		mA	Use buck regulator
Sleep1 mode current		0.26		mA	Use buck regulator
Sleep2 mode current		0.26		mA	Use buck regulator
GNSS low power mode					
Satellite tracking average current	2.6		8.2	mA	Use buck regulator @GSOP command Sleep1 and normal mode cycle
I2C slave					I2C clock : 400kHz Address length : 7 bits Slave address : 0x24
Default Baud Rate		115200		bps	8,N,1
Digital input level high	0.7*VDD		VDD+0.3	V	VIH
Digital input level low	-0.3		0.3*VDD	V	VIL
Digital output level high	0.8*VDD		VDD	V	VOH 2mA
Digital output level low	0		0.2*VDD	V	VOL 2mA
Flash size		16		M-bit	
GNSS Center Frequency		1561.098 1575.42 1602.5625		MHz	BeiDou GPS Glonass
Navigation update rate		1		Hz	
Accuracy		1		M	Signal strength is -130dBm
Cold starts		35		Sec.	Signal strength is -130dBm
Hot starts		1		Sec.	
Tracking Sensitivity		-161		dBm	

Hot starts Sensitivity		-160		dBm	
Cold starts Sensitivity		-147		dBm	
Operating Temperature	-40	25	+85	°C	
Dimensions					11mm*8mm*2.2mm
Weight		0.37		g	

REFLOW SOLDERING

Consider the "IPC-7530 Guidelines for temperature profiling for mass soldering (reflow and wave) processes, published 2001.

Preheat phase

Initial heating of component leads and balls. Residual humidity will be dried out. Please note that this preheat phase will not replace prior baking procedures.

- Temperature rise rate: max. 3 °C/s If the temperature rise is too rapid in the preheat phase it may cause excessive slumping.
- Time: 60 - 120 s If the preheat is insufficient, rather large solder balls tend to be generated. Conversely, if performed excessively, fine balls and large balls will be generated in clusters.
- End Temperature: 150 - 200 °C If the temperature is too low, non-melting tends to be caused in areas containing large heat capacity.

Heating/ Reflow phase

The temperature rises above the liquidus temperature of 217°C. Avoid a sudden rise in temperature as the slump of the paste could become worse.

- Limit time above 217 °C liquidus temperature: 40 - 60 s
- Peak reflow temperature: 245 °C

Cooling phase

A controlled cooling avoids negative metallurgical effects (solder becomes more brittle) of the solder and possible mechanical tensions in the products. Controlled cooling helps to achieve bright solder fillets with a good shape and low contact angle.

- Temperature fall rate: max 4 °C/s To avoid falling off, the REYAX module should be placed on the topside of the motherboard during soldering.

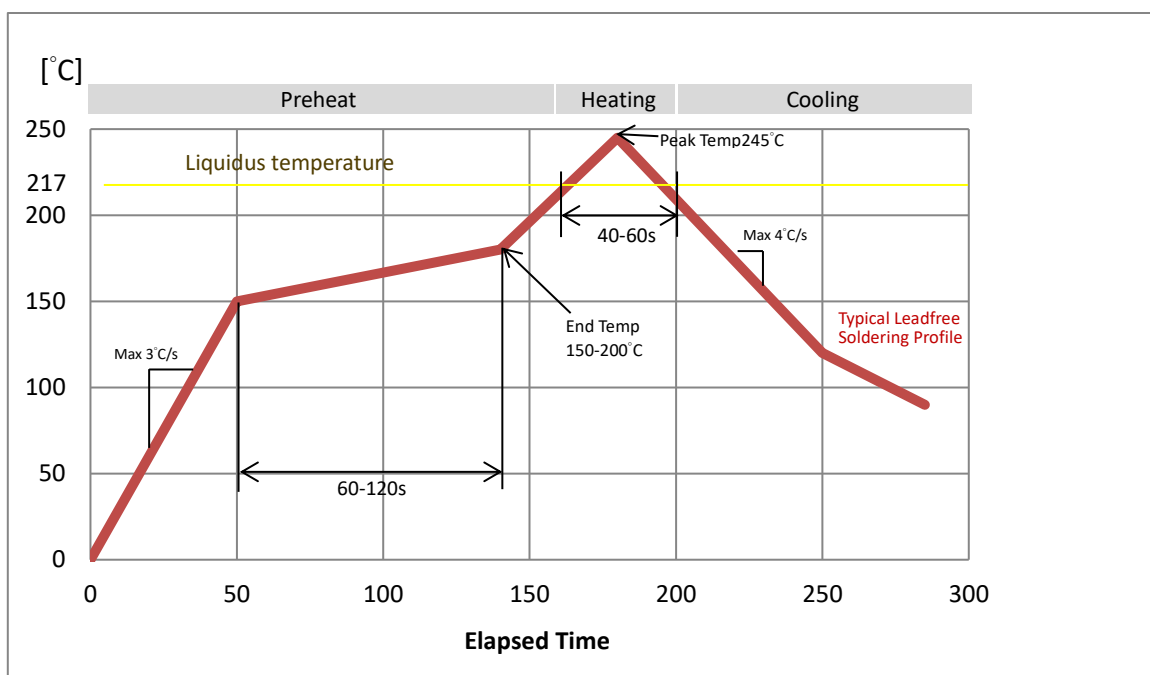

Recommended soldering profile

DIMENSIONS

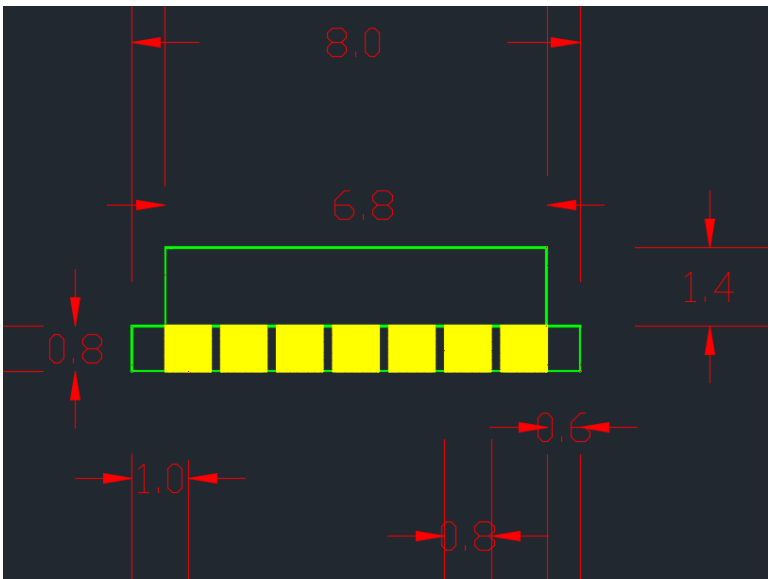
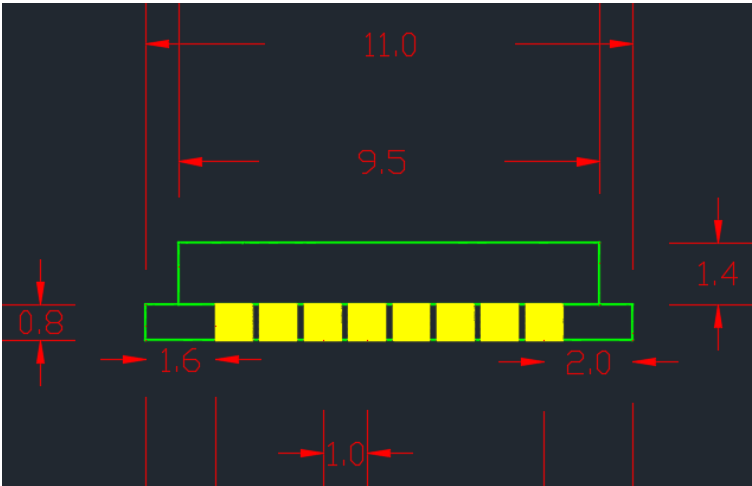
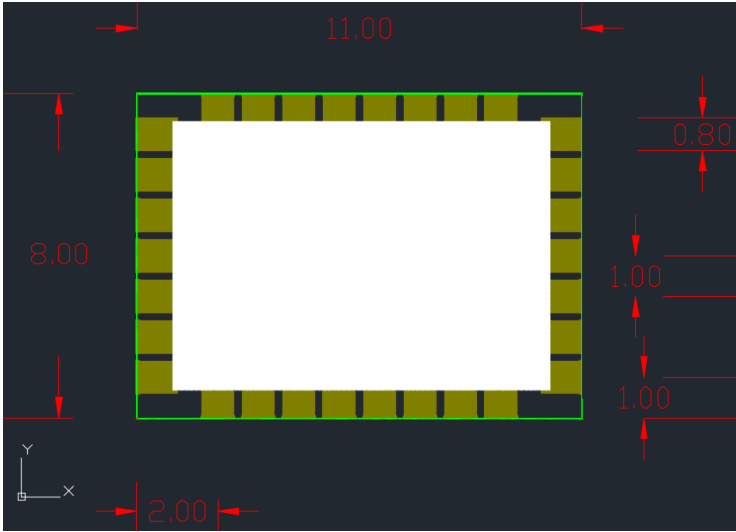

Unit : mm

LAYOUT FOOTPRINT RECOMMENDATIONS

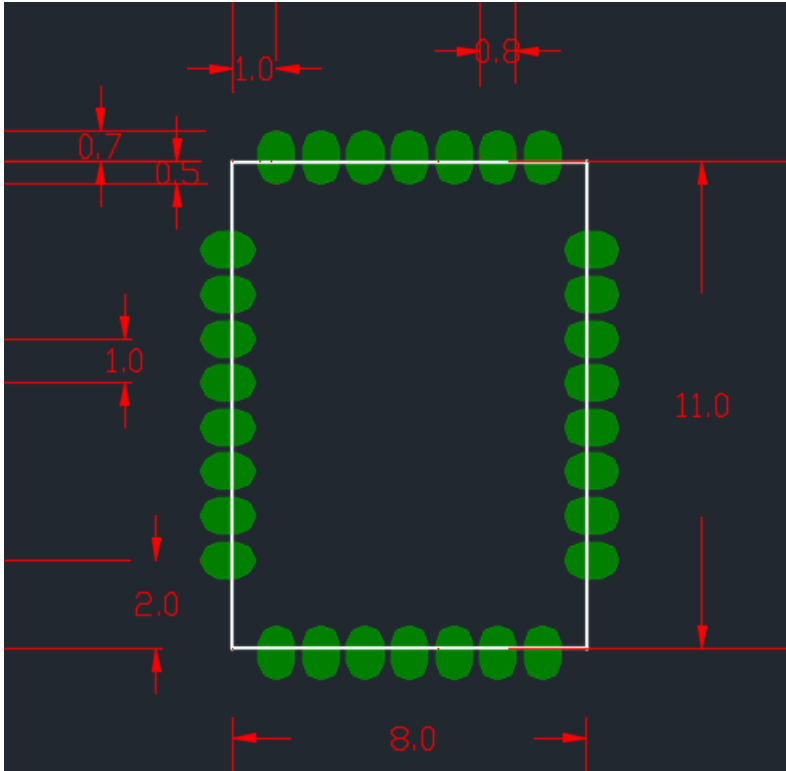

Unit : mm

GNSS Monitor software

After Install GNSS_MonitorForCustomerSetup.exe, Please open a dialog window by selecting "Setup(S)"->"Serial Port(S)". Then you should put following parameter on the window

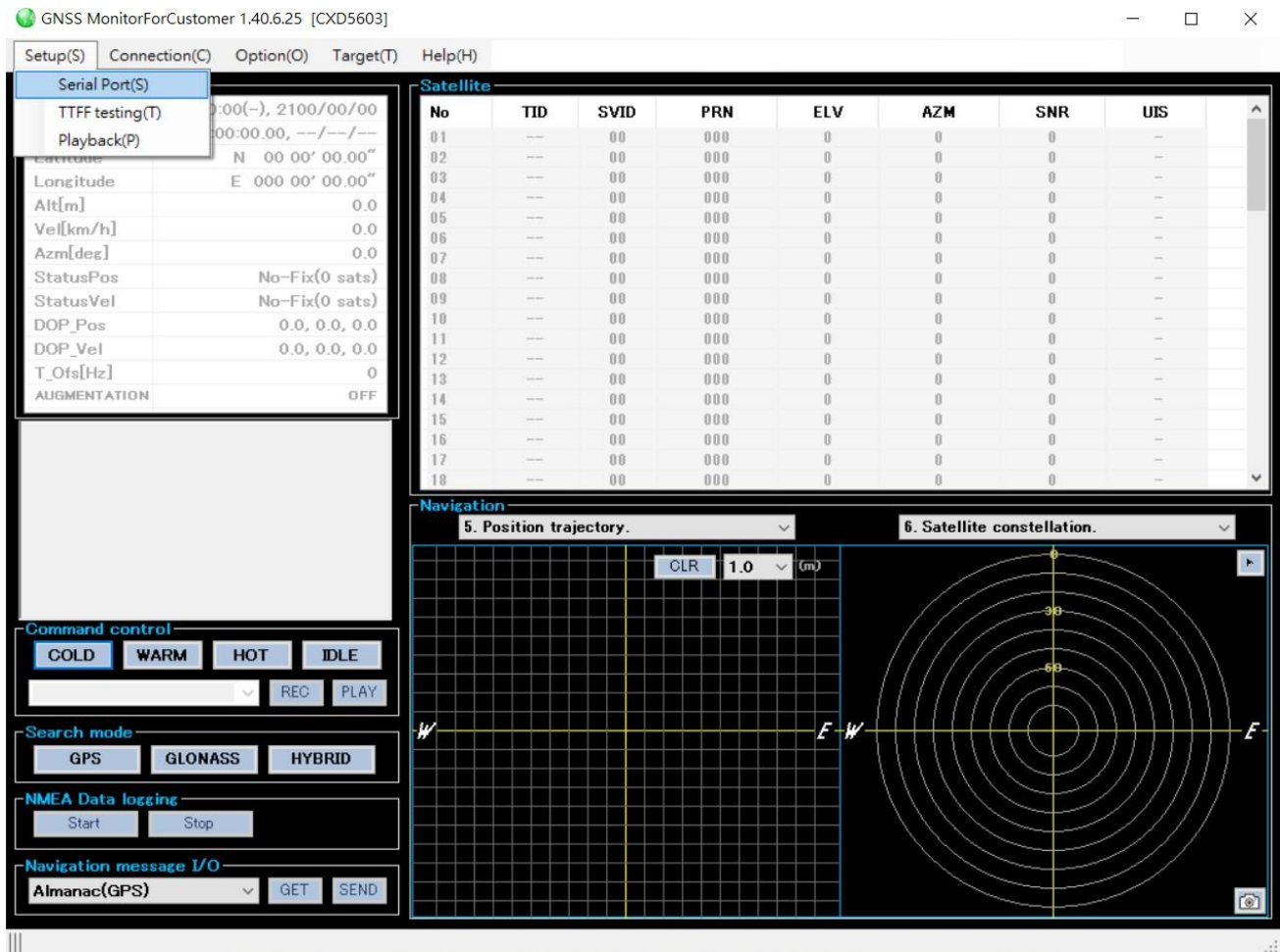

- Port Number: This depends on your PC system.
- Baud rate: 115200
- Data: 8bit
- Stop: 1bit
- Parity: None
- Flow control: None
- Read Timeout(sec): Unlimited
- RtsEnable: False
- DtrEnable: False
- Line feed code
- Receive: LF
- transmit: CR+LF

QUICK START GUIDE

Search mode select

A click of Cold/Warm/Hot button in command control area of GNSS monitor will start to fix position. Please move to Idle mode and assert Cold start in case of changing search mode. It is possible to input a command directly from a command input window.

Hot start : @GSR

Warm start : @GSW

Cold start : @GCD

IDLE mode : @GSTP

Command input procedure

In the case of use communication terminal software other than a GNSS monitor, positioning operation will be started if a command is inputted below. It is required to key in "enter" or "\r\n" in the end of all Commands.

Ex.) Baud rate : 115200bps, Normal mode, GPS+GLONASS search mode

@GSTP (Set IDLE Mode)

@GPPS 1 (Set PPS output setting)

@GTIM 2020 07 04 13 30 30<CR><LF> // UTC 2020/07/04 13:30:30

@GNS 03 (Set GPS+GLONASS search mode)

@GSR (hot start)

Please change the operation mode in IDLE mode. And after changing operation mode, please execute Hot start.

Low power mode

When change to Low Power Mode, please change the operation mode in IDLE mode.

@GSTP (Set IDLE Mode)

@GSOP 1 10000 5000 (positioning cycle of 10 second, sleep time of 5 second.)

@GSR (hot start)